



Installation Operation Maintenance

ODYSSEY

Light Commercial
Split System 5-20 Tons
TTH Model 50 Hz / 60 Hz



Air Handling Models

R22 Series

TTH 060 BD / TTH 060 B3
TTH 075 BD / TTH 075 B3
TTH 100 BD / TTH 100 B3
TTH 120 BD / TTH 120 B3
TTH 160 BD / TTH 160 B3
TTH 180 BD / TTH 180 B3
TTH 210 BD / TTH 210 B3
TTH 240 BD / TTH 240 B3

R407C Series

TTH 060 ED / TTH 060 E3
TTH 075 ED / TTH 075 E3
TTH 100 ED / TTH 100 E3
TTH 120 ED / TTH 120 E3
TTH 160 ED / TTH 160 E3
TTH 180 ED / TTH 180 E3
TTH 210 ED / TTH 210 E3
TTH 240 ED / TTH 240 E3

R407C Series (Hi-Eff)

TTH 060 FD
TTH 120 FD

June 2014

TTH-IOM01-EN



Model Nomenclature

Air Handling Unit Model Nomenclature

T T H 0 6 0 B D 0 0 B A

TTH = Cooling Only Air Handling Unit
(Horizontal Discharge)

Nominal Gross Cooling Capacity (MBH)

- 060 = 60 MBH
- 075 = 75 MBH
- 100 = 100 MBH
- 120 = 120 MBH
- 160 = 160 MBH
- 180 = 180 MBH
- 210 = 210 MBH
- 240 = 210 MBH

Major Design Sequence

- B = R22 Refrigerant
- E = R407C Refrigerant
- F = R407C (Hi-Eff)

Service Digit

- A = First Parts List

Minor Design Sequence

- A = First Design Sequence
- B = Second Design Sequence

Factory Installed Options # 2

- 0 = No Options
- A = Discharge Plenum

Factory Installed Options # 1

- 0 = No Options
- A = 1 HP Fan Motor
- B = 2 HP Fan Motor
- C = 3 HP Fan Motor
- D = 5 HP Fan Motor
- E = 7.5 HP Fan Motor

Electrical Characteristics

- D = 380-415/3/50
- 3 = 230/3/60
- K = 380/3/60
- 4 = 460/3/60

Contents

Model Nomenclature	2
General Information	4
Unit Installation	5
General Data	7
Electrical Wiring	12
Dimensional Data	13
Operation and Start-up	20
Maintenance	21
Trouble Shooting	22



General Information

Foreword

These instructions do not attempt to cover all variations in systems, nor to provide for every possible contingency to be met in connection with installation. Should further information be desired or should particular problems arise which are not sufficiently covered for the purchaser's purpose, the matter should be referred to the manufacturer.

Reception

On arrival, inspect the unit before signing the delivery note. Specify any damage on the delivery note, and send a registered letter of protest to the last carrier of the goods within 72 hours of delivery. Notify the local Trane Sales Office at the same time. The unit should be totally inspected within 15 days of delivery. If any concealed damage is discovered, stop unpacking the shipment. Take photos of the damage material if possible. Notify the carrier immediately by phone and registered mail. Notify the local Trane Sales Office. Concealed damage must be reported within 15 days of delivery. Check the unit nameplate to confirm that the proper unit was shipped. Available power supply must be compatible with electrical characteristics specified on component nameplates.

General Information

This manual covers the Installation, Operation, and Maintenance of the TTH060B, TTH075B, TTH100B, and TTH120B single circuit air handlers. These new air handler models are completely redesigned to incorporate a single slab coil assembly, improved application flexibility, servicing and maintenance accessibility, and an improved accessory line. They are horizontal type with special drain pan (for TTH model).

Note

"Warnings" and "Cautions" appear at appropriate places in this manual. Your personal safety and the proper operation of this machine require that you follow them carefully. The manufacturer assumes no liability for installations or servicing performed by unqualified personnel.

Handling

The unit will be supplied with a shipping base and protective packaging over the unit casing. The packaging should be kept on the unit during handling or storage on site.

If it is necessary to remove the packaging for inspection prior to completion of on site handling, retain packaging parts and reapply them by tapping in position to prevent damage to the casing. The unit as supplied has a shipping base which is suitable for handling by a fork lift truck. If it is necessary to sling the unit, use spreader bars under the shipping base.

Ensure that ropes do not cause abrasion to the surface of the unit.

Warning

Open and lock unit disconnect to prevent injury or death from electric shock or contact with moving parts before attempting any installation or maintenance.

Inspection

Inspect material carefully for any shipping damage. If damaged, it must be reported to, and claims made against the transportation company. Replace damaged parts with authorized parts only. Check the unit nameplate to confirm that the proper unit was shipped. Available power supply must be compatible with electrical characteristics specified on component nameplates.

Unit Installation

Warning

Open and lock unit disconnect to prevent injury or death from electric shock or contact with moving parts before attempting any installation or maintenance.

The general location of the air handler is normally selected by the architect, contractor, and/or buyer. For proper installation, the following items must be considered.

1. Available power supply must agree with electrical data on component nameplate.
2. Air handler shipped wired for 380 Volt applications.
3. If external accessories are installed on the unit, additional clearance must be provided.
4. All duct work should be properly insulated to prevent condensation and heat loss.

Note

It is recommended that the outline drawings be studied and dimensions properly noted and checked against selected installation site.

Important

If adding external accessories to the unit, additional clearance must be considered for the overall space needed.

Lifting Recommendations

Before preparing the unit for lifting, the center of gravity should be determined for lifting safety. Because of the placement of internal components, the unit weight may be unevenly distributed. Approximate to total unit weight and corner weight are given in Table 1.

Warning

On site Lifting Equipment must be capable of lifting the weight of the unit with an adequate safety factor. The use of under-capacity lifting devices may result in personal injury or death and cause damage to the unit.

Table 1 - Unit weight and corner weight (Kg)

Model	Net weight (Kg) Maximum	Corner weight (Kg)			
		#1	#2	#3	#4
TTH060FD	91	21	20	25	25
TTH120FD	177	40	40	49	47
TTH060	87	20	20	24	23
TTH075	91	21	20	25	25
TTH100	135	31	30	37	36
TTH120	140	32	32	39	38
TTH160	172	40	39	47	46
TTH180	181	41	41	50	49
TTH210	210	48	48	50	56
TTH240	239	55	54	66	64

The unit can be moved using a forklift of suitable capacity. For lifting the unit into an elevated mounting position, run lifting straps or slings under the unit and attach securely to the lifting device. Use spreader bars to protect the unit casing from damage. Test lift the unit to determine proper balance and stability.

Caution

Use spreader bars to prevent straps from damaging the unit, install the bars between lifting straps, both underneath the unit and above the unit. This will prevent the straps from crushing the unit cabinet or damaging the unit finish.

Installation Considerations

For proper installation and operation, check each of the following before mounting the units.

(a) Space Requirement and Clearances

Allow adequate space for the unit and free air or service clearance. See Figure 1a and 1b.

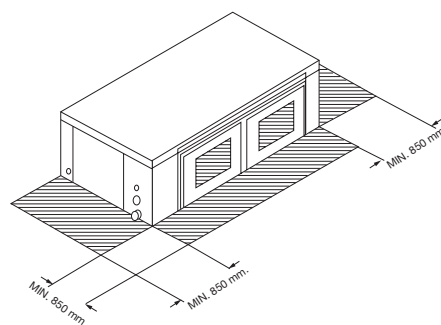

Figure 1a

For servicing and routine maintenance, provide access to the unit through removable panels in the ceiling see Figure 1b.

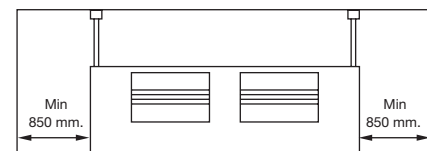

Figure 1b

(b) Location, Mounting and Positioning

Before installing any unit make sure proper preparation has been made at each unit locating for piping and electrical connections.

The unit should be installed in horizontal applications only. Suspend the unit using the factory-provided threaded mounting holes on bottom of the unit. This is usually accomplished through the use of spring or rubber isolators. Which are to be furnished by the installer see Figure 2.

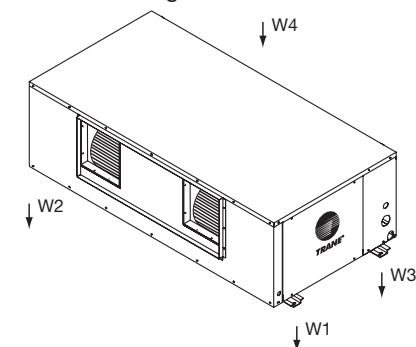

Figure 2
Position of corner weight
TTH model

Unit Installation

Check that the supporting structure is strong enough to support unit weights.

Align the mounting holes with structural support and secure suspension rods, to the structure, to the air handler cabinet. If the mounting holes locations do not permit proper alignment with existing structure, it may be necessary to field fabricate cross members on existing structure beams.

All units must be mounted level to assure proper drainage and operation.

(c)Coil Piping Connections

All refrigerant piping connection are made outside the unit.

Caution

- Protect adjacent surfaces from heat damage, when brazing around the air handler.
- These air handlers are shipped with a holding charge of N₂ until refrigerant lines are ready to be connected.

All refrigerant suction line piping should be insulated.

Important

Ensure that the refrigerant lines passing through the cabinet are not resting on sharp sheet metal edges.

Installation, brazing, leak testing, and evacuation of refrigeration lines are covered in the installation instructions packaged with the outdoor unit. Read the instructions before beginning installation of refrigerant lines.

(d)Condensate Drain Connections

These air handlers come standard with a drain pan. Drain connections are provided on both sides of the air handlers.

For a typical drain trap assembly, see Figure 3 and 4.

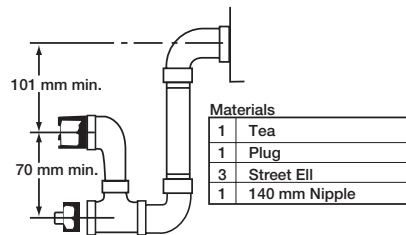

Figure 3
1 inch (25.4 mm) Galvanized Pipe and Fittings.

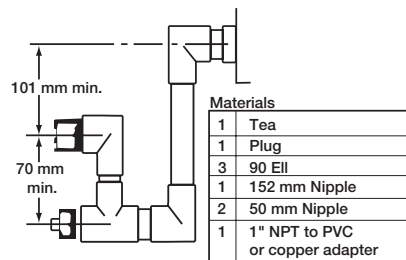

Figure 4
1 inch (25.4 mm) PVC or Copper Tubing and Fittings.

(e) Filters

These air handlers are shipped with 1" washable filters installed in the unit. To replace filters from either side and slide old filters and replace with new ones.

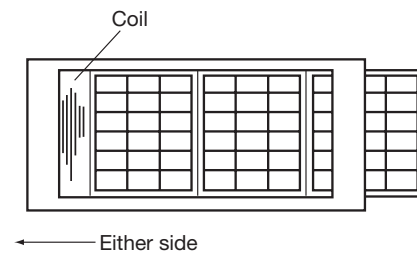

Figure 5

(f) Duct Connections

The supply and return ducts should be connected to the unit with flame retardant duct connectors to reduce vibration transmission. The return duct should be sized to the same dimensions as the return inlet of the unit.

(g) Electrical Connections

Warning: when installing or servicing this equipment, always exercise basic safety precautions to avoid the possibility of electric shock that could result in severe personal injury or death.

1. All electrical lines, sizing, protection and grounding must be in accordance with the National Electric Code and local codes.
2. If conduit is used, isolate whenever vibration transmission may cause a noise problem within the building structure.
3. Ensure all connections are tight and no wires exposed.
4. All accessories must be installed and wired according to the instructions packaged with that accessory.

Installation Checklist

Complete this checklist once the unit is installed to verify that all recommended procedures have been accomplished before the system is started. Operational checks cannot be performed until the system interconnection is complete.

- Verify that the unit electrical power is disconnected.
- Inspect all field wiring connections. All connections should be clean and tight.
- Inspect unit ground connection(s). Ground must comply with all applicable codes.
- Inspect unit suspension arrangement (if used). Unit position must be secure. Remove any tools or debris found in or near the unit.
- Inspect duct outlets. Outlets must be open and unrestricted.
- Inspect unit drain lines. Pipe connections must be tight and drain line unrestricted.
- Inspect fan assembly to insure all moving parts move freely.
- Inspect unit for proper filters, securely installed. All cabinet panels must be secured.
- Instruct owner/operator on proper system operating and maintenance procedure.



General Data

UNIT MODELS		TTH060FD	TTH120FD
POWER CONNECTION	V/ph/Hz	380-415/3/50	380-415/3/50
MCA¹	A	2.5	4.6
SYSTEM DATA			
Refrigerant Type		R407C	R407C
No. Refrigerant Circuits		1	1
Refrigerant Connection Type		BRAZE	BRAZE
Suction Line OD	in (mm)	1 1/8 (28.57)	1 3/8 (34.93)
Liquid line OD	in (mm)	1/2 (12.7)	1/2 (12.7)
CASING			
Material		Galvanized & Electro-galvanized Steel	
Color		Light Gray	
Type of Insulation		PE foam 10 mm with 0.03 g/cm ³ density	
COIL			
Face Area	sq ft (m ²)	5.06 (0.47)	11.19(1.04)
Tube Size OD	in (mm)	5/16 (7.94)	5/16 (7.94)
Tube Type		INNER GROOVED TUBE	
Rows		4	4
Fin Type		UNCOATED SLIT	
Fins per inch		15	14
Refrigerant Flow Control		EXPANSION VALVE	EXPANSION VALVE
Drain Connection Size	in (mm)	1 (25.4)	1 (25.4)
Drain Connection Type		STEEL PIPE - MPT	
ELECTRIC HEATER DATA			
Heater Rating	kW	-	-
Heater RLA		-	-
FAN			
Fan Type		DOUBLE INLET CENTRIFUGAL WITH FORWARD CURVED WHEEL	
No. used		1	2
Diameter	in (mm)	10 (254)	12 (304.8)
Width	in (mm)	10 (254)	12 (304.8)
Drive Type		BELT-ADJUSTABLE DRIVE	
Nominal Airflow ²	cfm	2000	4000
MOTOR			
Motor Type		TOTALLY ENCLOSED-FAN COOLED THREE PHASE INDUCTION MOTOR	
No. of Motor		1	1
Motor hp	hp (kW)	3/4 (0.55)	2 (1.5)
No. of Speed		1	1
Motor Speed	rpm	1405	1405
V/ph/Hz		380-415/3/50	380-415/3/50
RLA/LRA		1.61-8.40	3.67-22.02
FILTER			
Type		WASHABLE ALUMINUM AIR FILTER	
No. used		2	3
Size (WxLxD)	mm	440 X 600 X 25	697 x 598 x 22
DIMENSION (HxWxD)			
Crated (Shipping)	mm	673 x 1,410 x 970	945x 2162 x 1264
Uncrated (Net)	mm	520 x 1,406 x 916	798 x 2059 x 1260
WEIGHT			
Uncrated (Net)	kg	92	172

¹ MCA - Minimum Circuit Ampacity

² CFM is rated with standard air-dry coil.



General Data

UNIT MODELS		TTH060BD/ED	TTH075BD/ED	TTH100BD/ED	TTH120BD/ED
POWER CONNECTION	V/ph/Hz	380-415/3/50	380-415/3/50	380-415/3/50	380-415/3/50
MCA¹	A	2.0	2.5	4.6	4.6
SYSTEM DATA					
Refrigerant Type		R22/R407C	R22/R407C	R22/R407C	R22/R407C
No. Refrigerant Circuits		1	1	1	1
Refrigerant Connection Type		BRAZE	BRAZE	BRAZE	BRAZE
Suction Line OD	in (mm)	1 1/8 (28.57)	1 1/8 (28.57)	1 3/8 (34.93)	1 3/8 (34.93)
Liquid line OD	in (mm)	3/8 (9.53)	1/2 (12.7)	1/2 (12.7)	1/2 (12.7)
CASING					
Material		Galvanized & Electro-galvanized Steel			
Color		Light Gray			
Type of Insulation		PE foam 10 mm with 0.03 g/cm ³ density			
COIL					
Face Area	sq ft (m ²)	4.22 (0.39)	5.06 (0.47)	6.67 (0.62)	8.19 (0.76)
Tube Size OD	in (mm)	5/16 (7.94)	5/16 (7.94)	5/16 (7.94)	5/16 (7.94)
Tube Type		INNER GROOVED TUBE			
Rows		3	3	3	3
Fin Type		UNCOATED SLIT			
Fins per inch		15	15	15	15
Refrigerant Flow Control		CAP. TUBE	EXPANSION VALVE	EXPANSION VALVE	EXPANSION VALVE
Drain Connection Size	in (mm)	1 (25.4)	1 (25.4)	1 (25.4)	1 (25.4)
Drain Connection Type		STEEL PIPE - MPT			
ELECTRIC HEATER DATA					
Heater Rating	kW	-	-	-	-
Heater RLA		-	-	-	-
FAN					
Fan Type		DOUBLE INLET CENTRIFUGAL WITH FORWARD CURVED WHEEL			
No. used		1	1	2	2
Diameter	in (mm)	10 (254)	10 (254)	10 (254)	10 (254)
Width	in (mm)	10 (254)	10 (254)	8 (203.2)	10 (254)
Drive Type		BELT-ADJUSTABLE DRIVE			
Nominal Airflow ²	cfm	2000	2500	3400	4000
MOTOR					
Motor Type		TOTALLY ENCLOSED-FAN COOLED THREE PHASE INDUCTION MOTOR			
No. of Motor		1	1	1	1
Motor hp	hp (kW)	3/4 (0.55)	1 (0.75)	2 (1.5)	2 (1.5)
No. of Speed		1	1	1	1
Motor Speed	rpm	1405	1400	1405	1405
V/ph/Hz		380-415/3/50	380-415/3/50	380-415/3/50	380-415/3/50
RLA/LRA		1.61-8.40	1.99 - 11.0	3.66 - 21.0	3.66 - 21.0
FILTER					
Type		WASHABLE ALUMINUM AIR FILTER			
No. used		2	2	3	3
Size (WxLxD)	mm	440 X 520 X 25	440 X 600 X 25	440 X 520 X 25	542 X 520 X 25
DIMENSION (HxWxD)					
Crated (Shipping)	mm	673 x 1,410 x 970	673 x 1,410 x 970	673 x 1,778 x 970	772 x 1,778 x 970
Uncrated (Net)	mm	520 x 1,406 x 916	520 x 1,406 x 916	520 x 1,774 x 916	620 x 1,774 x 916
WEIGHT					
Uncrated (Net)	kg	87	92	136	141

¹ MCA - Minimum Circuit Ampacity

² CFM is rated with standard air-dry coil.



General Data

UNIT MODELS		TTH160BD/ED	TTH180BD/ED	TTH210BD/ED	TTH240BD/ED
POWER CONNECTION		V/ph/Hz	380-415/3/50	380-415/3/50	380-415/3/50
MCA¹		A	4.6	6.4	6.4
SYSTEM DATA					
Refrigerant Type		R22/R407C	R22/R407C	R22/R407C	R22/R407C
No. Refrigerant Circuits		1	2	2	2
Refrigerant Connection Type		BRAZE	BRAZE	BRAZE	BRAZE
Suction Line OD		in (mm)	1 5/8 (41.3)	1 3/8 (34.93)	1 3/8 (34.93)
Liquid line OD		in (mm)	5/8 (15.9)	1/2 (12.7)	1/2 (12.7)
CASING					
Material		Galvanized & Electro-galvanized Steel			
Color		Light Gray			
Type of Insulation		PE foam 10 mm with 0.03 g/cm ³ density			
COIL					
Face Area		sq ft (m ²)	11.19(1.04)	12.28(1.14)	13.6 (1.27)
Tube Size OD		in (mm)	5/16 (7.94)	5/16 (7.94)	5/16 (7.94)
Tube Type		INNER GROOVED TUBE			
Rows		3	3	3	3
Fin Type		UNCOATED SLIT			
Fins per inch		14	14	14	14
Refrigerant Flow Control		EXPANSION VALVE	EXPANSION VALVE	EXPANSION VALVE	EXPANSION VALVE
Drain Connection Size		in (mm)	1 (25.4)	1 (25.4)	1 (25.4)
Drain Connection Type		STEEL PIPE - MPT			
ELECTRIC HEATER DATA					
Heater Rating		kW	-	-	-
Heater RLA			-	-	-
FAN					
Fan Type		DOUBLE INLET CENTRIFUGAL WITH FORWARD CURVED WHEEL			
No. used		2	2	2	2
Diameter		in (mm)	12 (304.8)	12 (304.8)	15 (381)
Width		in (mm)	12 (304.8)	12 (304.8)	15 (381)
Drive Type		BELT-ADJUSTABLE DRIVE			
Nominal Airflow ²		cfm	5300	6000	7000
MOTOR					
Motor Type		TOTALLY ENCLOSED-FAN COOLED THREE PHASE INDUCTION MOTOR			
No. of Motor		1	1	1	1
Motor hp		hp (kW)	2(1.5)	3 (2.2)	3 (2.2)
No. of Speed		1	1	1	1
Motor Speed		rpm	1405	1425	1425
V/ph/Hz			380-415/3/50	380-415/3/50	380-415/3/50
RLA/LRA			3.66-21	5.08-34	5.08-34
FILTER					
Type		WASHABLE ALUMINUM AIR FILTER			
No. used		3	3	4	4
Size (WxLxD)		mm	697 x 598 x 22	697 x 598 x 22	520 x 745 x 22
DIMENSION (HxWxD)					
Crated (Shipping)		mm	945x 2162 x 1264	945x 2162 x 1264	980x 2471 x 1325
Uncrated (Net)		mm	798 x 2059 x 1260	798 x 2059 x 1260	849 x 2366x 1319
WEIGHT					
Uncrated (Net)		kg	172.0	181.0	210.0

¹ MCA - Minimum Circuit Ampacity

² CFM is rated with standard air-dry coil.



General Data

UNIT MODELS		TTH060B3/E3	TTH075B3/E3	TTH100B3/E3	TTH120B3/E3
POWER CONNECTION	V/ph/Hz	230/3/60	230/3/60	230/3/60	230/3/60
MCA¹	A	3.2	4.0	7.3	7.5
SYSTEM DATA					
Refrigerant Type		R22	R22	R22	R22
No. Refrigerant Circuits		1	1	1	1
Refrigerant Connection Type		BRAZE	BRAZE	BRAZE	BRAZE
Suction Line OD	in (mm)	1 1/8 (28.57)	1 1/8 (28.57)	1.3/8 (34.93)	1.3/8 (34.93)
Liquid line OD	in (mm)	3/8 (9.53)	1/2 (12.7)	1/2 (12.7)	1/2 (12.7)
CASING					
Material		Galvanized & Electro-galvanized Steel			
Color		Light Gray			
Type of Insulation		PE foam 10 mm			
COIL					
Face Area	sq ft (m ²)	4.22 (0.39)	5.06 (0.47)	6.67 (0.62)	8.19 (0.76)
Tube Size OD	in (mm)	5/16 (7.94)	5/16 (7.94)	5/16 (7.94)	5/16 (7.94)
Tube Type		INNER GROOVED TUBE			
Rows		3	3	3	3
Fin Type		SLIT COATED FIN			
Fins per inch		15	15	15	15
Refrigerant Flow Control		CAP. TUBE	EXPANSION VALVE	EXPANSION VALVE	EXPANSION VALVE
Drain Connection Size	in (mm)	1 (25.4)	1 (25.4)	1 (25.4)	1 (25.4)
Drain Connection Type		STEEL PIPE - MPT			
ELECTRIC HEATER DATA					
Heater Rating	kW	-	-	-	-
Heater RLA		-	-	-	-
FAN					
Fan Type		DOUBLE INLET CENTRIFUGAL WITH FORWARD CURVED WHEEL			
No. used		1	1	2	2
Diameter	in (mm)	10 (254)	10 (254)	10 (254)	10 (254)
Width	in (mm)	10 (254)	10 (254)	8 (203.2)	10 (254)
Drive Type		BELT-ADJUSTABLE DRIVE			
Nominal Airflow ²	cfm	2000	2500	3400	4000
MOTOR					
Motor Type		TOTALLY ENCLOSED-FAN COOLED, THREE PHASE INDUCTION MOTOR			
No. of Motor		1	1	1	1
Motor hp	hp (kW)	3/4 (0.55)	1 (0.75)	2 (1.5)	2 (1.5)
No. of Speed		1	1	1	1
Motor Speed	rpm	1670	1690	1705	1700
V/ph/Hz		230/3/60	230/3/60	230/3/60	230/3/60
RLA/LRA		2.53-14.5	3.16-19.5	5.85-39	3.66 - 36.0
FILTER					
Type		WASHABLE ALUMINUM AIR FILTER			
No. used		2	2	3	3
Size (WxLxD)	mm	440 X 520 X 25	440 X 600 X 25	440 X 520 X 25	542 X 520 X 25
DIMENSION (HxWxD)					
Crated (Shipping)	mm	673 x 1,410 x 970	673 x 1,410 x 970	673 x 1,778 x 970	772 x 1,778 x 970
Uncrated (Net)	mm	520 x 1,312 x 841	520 x 1,312 x 841	520 x 1,680 x 841	620 x 1,680 x 841
WEIGHT					
Uncrated (Net)	kg	87.0	90.0	134.0	141.0

¹ MCA - Minimum Circuit Ampacity

² CFM is rated with standard air-dry coil.



General Data

UNIT MODELS		TTH160B3/E3	TTH180B3/E3	TTH210B3/E3	TTH240B3/E3
POWER CONNECTION		V/ph/Hz	230/3/60	230/3/60	230/3/60
MCA¹		A	7.5	10.5	10.5
SYSTEM DATA					
Refrigerant Type		R22/R407C	R22/R407C	R22/R407C	R22/R407C
No. Refrigerant Circuits		1	2	2	2
Refrigerant Connection Type		BRAZE	BRAZE	BRAZE	BRAZE
Suction Line OD		in (mm)	1 5/8 (41.3)	1 3/8 (34.93)	1 3/8 (34.93)
Liquid line OD		in (mm)	5/8 (15.9)	1/2 (12.7)	1/2 (12.7)
CASING					
Material		Galvanized & Electro-galvanized Steel			
Color		Light Gray			
Type of Insulation		PE foam 10 mm with 0.03 g/cm ³ density			
COIL					
Face Area		sq ft (m ²)	11.19(1.04)	12.28(1.14)	13.6 (1.27)
Tube Size OD		in (mm)	5/16 (7.94)	5/16 (7.94)	5/16 (7.94)
Tube Type		INNER GROOVED TUBE			
Rows		3	3	3	3
Fin Type		UNCOATED SLIT			
Fins per inch		14	14	14	14
Refrigerant Flow Control		EXPANSION VALVE	EXPANSION VALVE	EXPANSION VALVE	EXPANSION VALVE
Drain Connection Size		in (mm)	1 (25.4)	1 (25.4)	1 (25.4)
Drain Connection Type		STEEL PIPE - MPT			
ELECTRIC HEATER DATA					
Heater Rating		kW	-	-	-
Heater RLA			-	-	-
FAN					
Fan Type		DOUBLE INLET CENTRIFUGAL WITH FORWARD CURVED WHEEL			
No. used		2	2	2	2
Diameter		in (mm)	12 (304.8)	12 (304.8)	15 (381)
Width		in (mm)	12 (304.8)	12 (304.8)	15 (381)
Drive Type		BELT-ADJUSTABLE DRIVE			
Nominal Airflow ²		cfm	5300	6000	7000
MOTOR					
Motor Type		TOTALLY ENCLOSED-FAN COOLED THREE PHASE INDUCTION MOTOR			
No. of Motor		1	1	1	1
Motor hp		hp (kW)	2(1.5)	3 (2.2)	3 (2.2)
No. of Speed		1	1	1	1
Motor Speed		rpm	1700	1710	1710
V/ph/Hz			230/3/60	230/3/60	230/3/60
RLA/LRA			3.66-36.0	8.4-58.8	8.4-58.8
FILTER					
Type		WASHABLE ALUMINUM AIR FILTER			
No. used		3	3	4	4
Size (WxLxD)		mm	697 x 598 x 22	697 x 598 x 22	520 x 745 x 22
DIMENSION (HxWxD)					
Crated (Shipping)		mm	945x 2162 x 1264	945x 2162 x 1264	980x 2471 x 1325
Uncrated (Net)		mm	798 x 2059 x 1260	798 x 2059 x 1260	849 x 2366x 1319
WEIGHT					
Uncrated (Net)		kg	172.0	181.0	210.0

¹ MCA - Minimum Circuit Ampacity

² CFM is rated with standard air-dry coil.



Electrical Wiring

TTH060-240 (EXPORT)

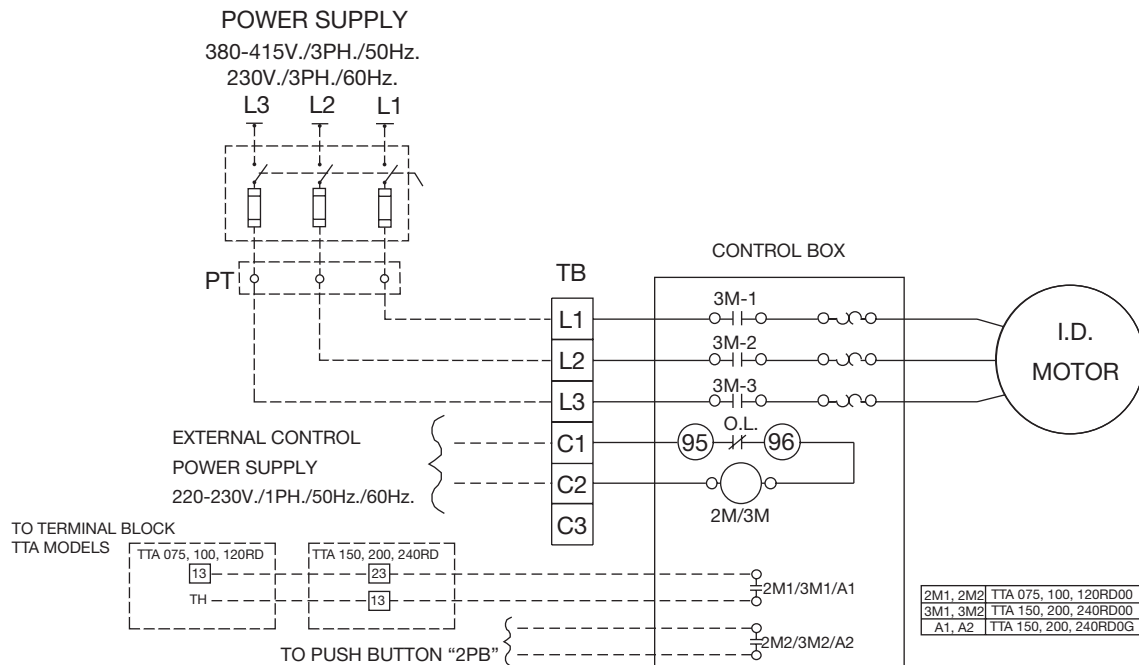

LEGEND	
DEVICE DESIGNATION	DESCRIPTION
1M	CONTACTOR BLOWER MOTOR.
TB	TERMINAL BLOCK
2M1, 2M2, 3M1	AUXILIARY N.O. CONTACT
3M2, A1, A2	AUXILIARY N.O. CONTACT
TH	THERMOSTAT
2PB	SWITCH PUSH BUTTON
—	FACTORY WIRING & DEVICE BY MFR.
----	FIELD WIRING
ID. MOTOR	INDUCTION MOTOR
PT	POWER TERMINAL
- _ -	FUSE

NOTES

1. ALL FIELD WIRING TO BE IN ACCORDANCE WITH NATIONAL ELECTRIC CODE (N.E.C.), CANADIAN ELECTRIC CODE AND/OR LOCAL STATE AND CITY CODES, PROVIDE DISCONNECTS FOR ALL POWER SUPPLIES.
2. DRAWING PRACTICES AND SYMBOLS ARE IN ACCORDANCE WITH AIR CONDITIONING & REFRIGERATION INSTITUTE (ARI) GRAPHIC ELECTRICAL STANDARDS.
3. COMPONENT TERMINAL MARKINGS ARE INDICATED BY ENCIRCLED NUMBERS AND/OR LETTERS.
4. NUMBERS ON VERTICAL & HORIZONTAL LINE ARE CIRCUIT IDENTIFICATION.
5. THIS UNIT TO BE USED WITH EVAPORATORS OPERATING WITH IN A TEMPERATURE RANGE OF 32° F TO 53.5° F.

TTH060-240 (DOMESTIC)

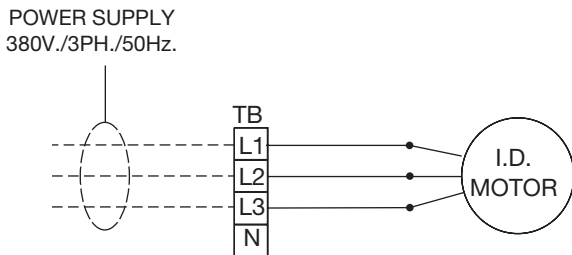

LEGEND	
DEVICE DESIGNATION	DESCRIPTION
TB	TERMINAL BLOCK
—	FACTORY WIRING & DEVICE BY MFR.
----	FIELD WIRING
ID. MOTOR	INDUCTION MOTOR 380V. 3PH. 50Hz.

Caution: Disconnect the power supply before opening the control box or servicing.

Dimensional Data

TTH 060 FD
TTH 060-075 BD / ED
TTH 060-075 B3 / E3

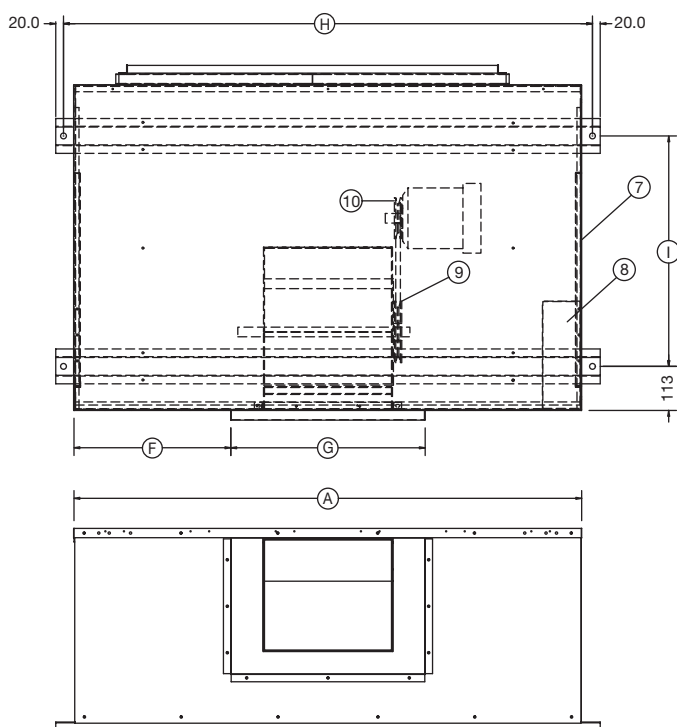
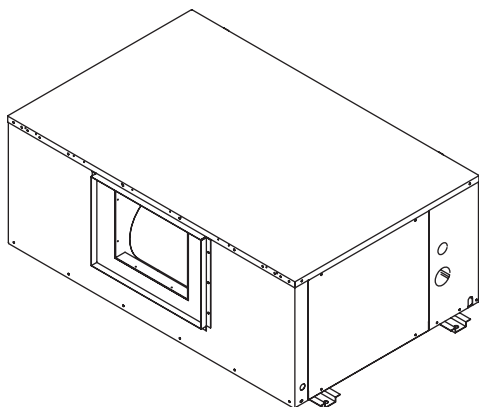

- ① LIQUID LINE Ø3/8" FOR TTH060
LIQUID LINE Ø1/2" FOR TTH075
- ② SUCTION LINE Ø1 1/8"
- ③ DRAIN TUBE Ø1"
- ④ HOLE FOR POWER WIRING Ø7/8" KO.
- ⑤ MOTOR
- ⑥ BLOWER
- ⑦ ACCESS PANEL
- ⑧ ELECTRICAL BOX
- ⑨ FAN PULLEY
- ⑩ MOTOR PULLEY
- ⑪ EVAPORATOR COIL
- ⑫ BELT

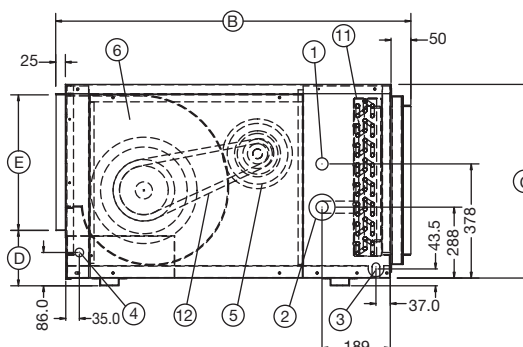

MODEL NO.	DIMENSIONS (MM)								
	A	B	C	D	E	F	G	H	I
TTH060	1312	916	520	143	352	405	502	1366	595
TTH075	1312	916	520	143	352	405	502	1366	595



Dimensional Data

TTH 100-120 BD / ED
TTH 100-120 B3 / E3

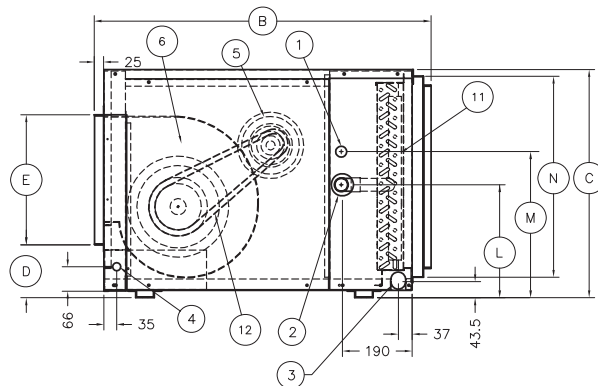
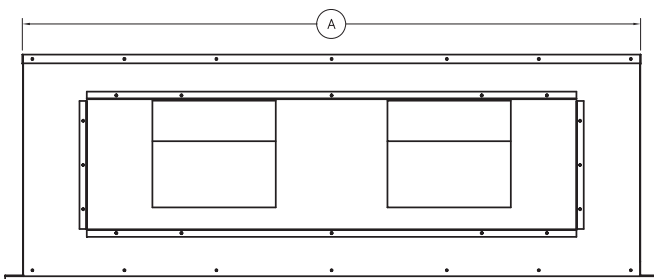
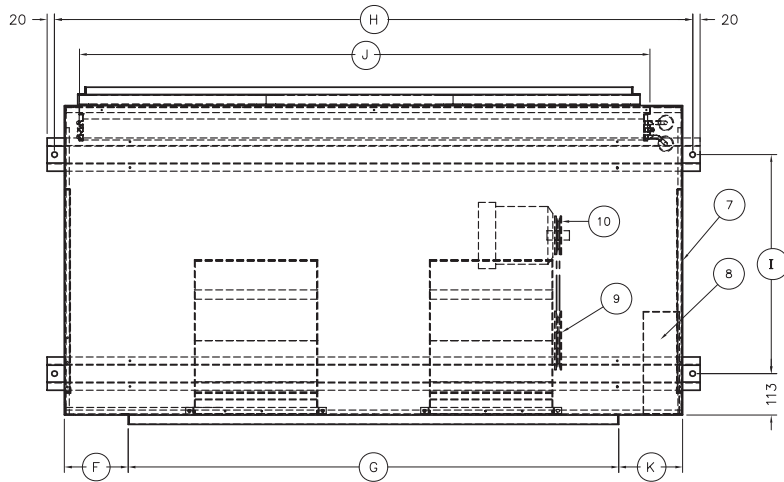
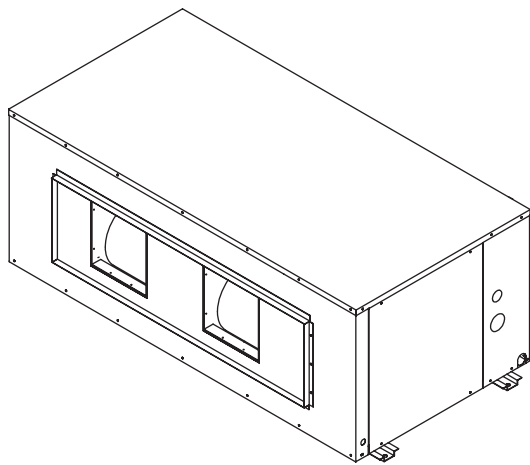

- ① LIQUID LINE $\phi 1/2"$ FOR TTH100/120
- ② SUCTION LINE $\phi 1 3/8"$
- ③ DRAIN TUBE $\phi 1"$
- ④ HOLE FOR POWER WIRING $\phi 7/8"$ KO.
- ⑤ MOTOR
- ⑥ BLOWER
- ⑦ ACCESS PANEL
- ⑧ ELECTRICAL BOX
- ⑨ FAN PULLEY
- ⑩ MOTOR PULLEY
- ⑪ EVAPORATOR COIL
- ⑫ BELT

Model No.	Dimensions (mm)													
	A	B	C	D	E	F	G	H	I	J	K	L	M	N
TTH100	1680	916	521	144	353	294	946	1734	595	1550	440	288	378	435
TTH120	1680	916	620	144	353	173	1332	1734	595	1522	173	307	397	545

Dimensional Data

TTH 160 - 180 BD/ED

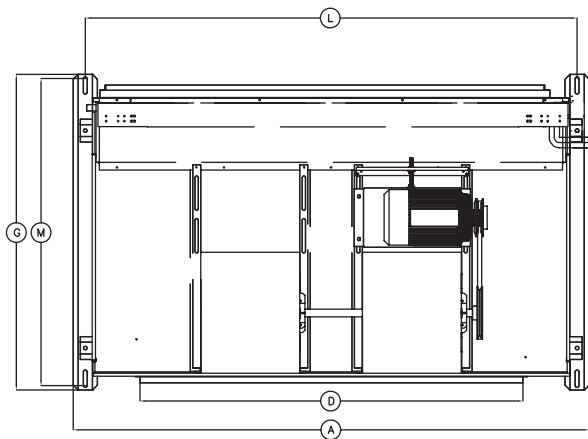
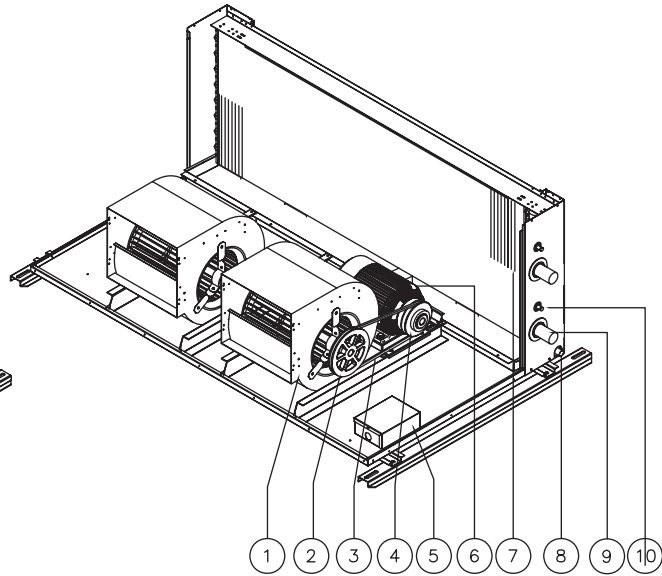
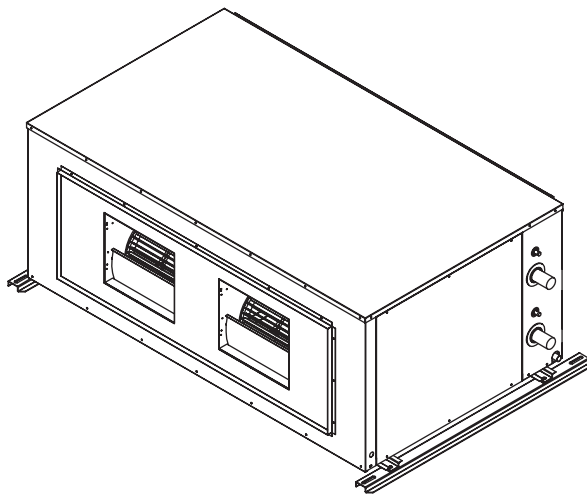

- 1 FAN COMPLETE
- 2 FAN PULLEY
- 3 BELT
- 4 MOTOR PULLEY
- 5 ELECTRICAL BOX
- 6 MOTOR
- 7 EVAPORATOR COIL
- 8 DRAIN TUBE $\phi 1"$
- 9 SUCTION
- 10 LIQUID

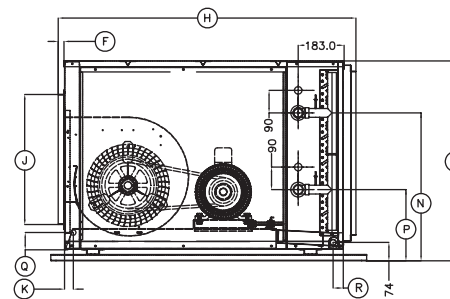
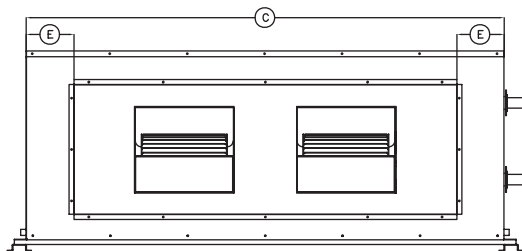

MODEL	DIMENSION (MILLIMETER)															
	A	B	C	D	E	F	G	H	J	K	L	M	N	P	Q	R
TTH160	2059	798	1912	1528	190	25	1260	1188	519	34	1962.5	1225	590.6	284.6	69	40
TTH180	2059	798	1912	1528	190	25	1260	1188	519	34	1962.5	1225	590.6	284.6	69	40



OUT LINE DIMENSION TTH210/TTH240

TTH210
TTH240

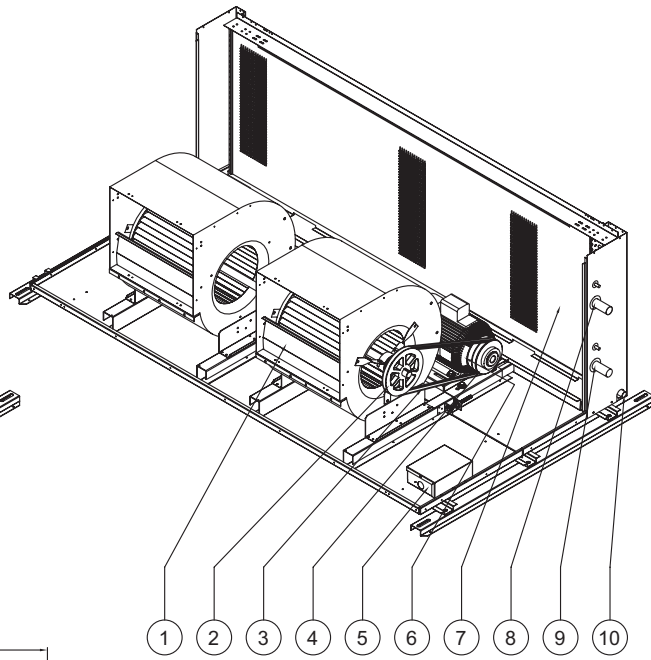
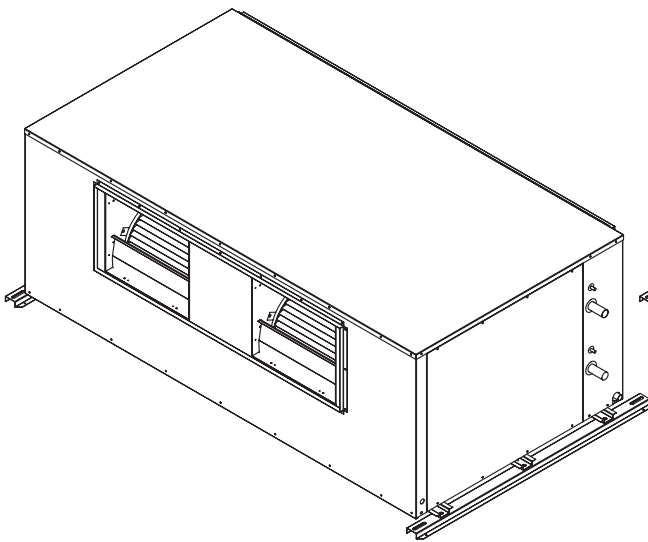

- ① FAN COMPLETE
- ② FAN PULLEY
- ③ BELT
- ④ MOTOR PULLEY
- ⑤ ELECTRICAL BOX
- ⑥ MOTOR
- ⑦ COIL EVAP
- ⑧ HEADER #1
- ⑨ HEADER #2
- ⑩ DRAIN TUBE Ø1"

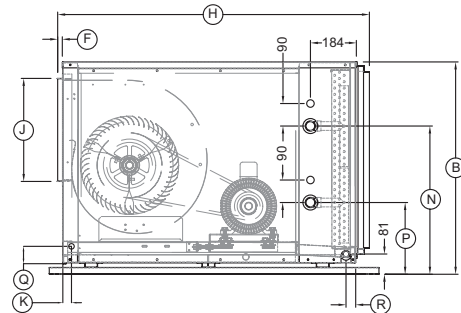
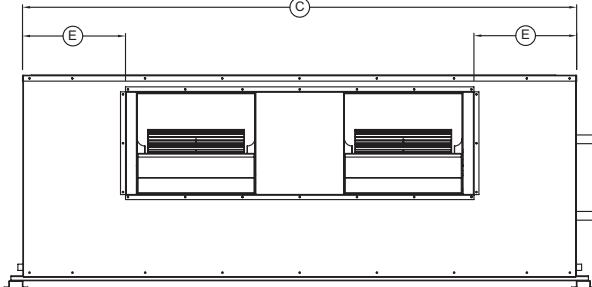

DIMENSIONAL DATA

MODEL	DIMENSION (MILLIMETER)																
	A	B	C	D	E	F	G	H	J	K	L	M	N	P	Q	R	
TTH210	2366	849	2217	1394	412	20	1319	1249	412	34	2271	1284	593	287	69	40	
TTH240	2366	849	2217	1394	412	20	1319	1249	412	34	2271	1284	593	287	69	40	

Dimensional Data

**TTH 060-120
With Plenum (Option)**

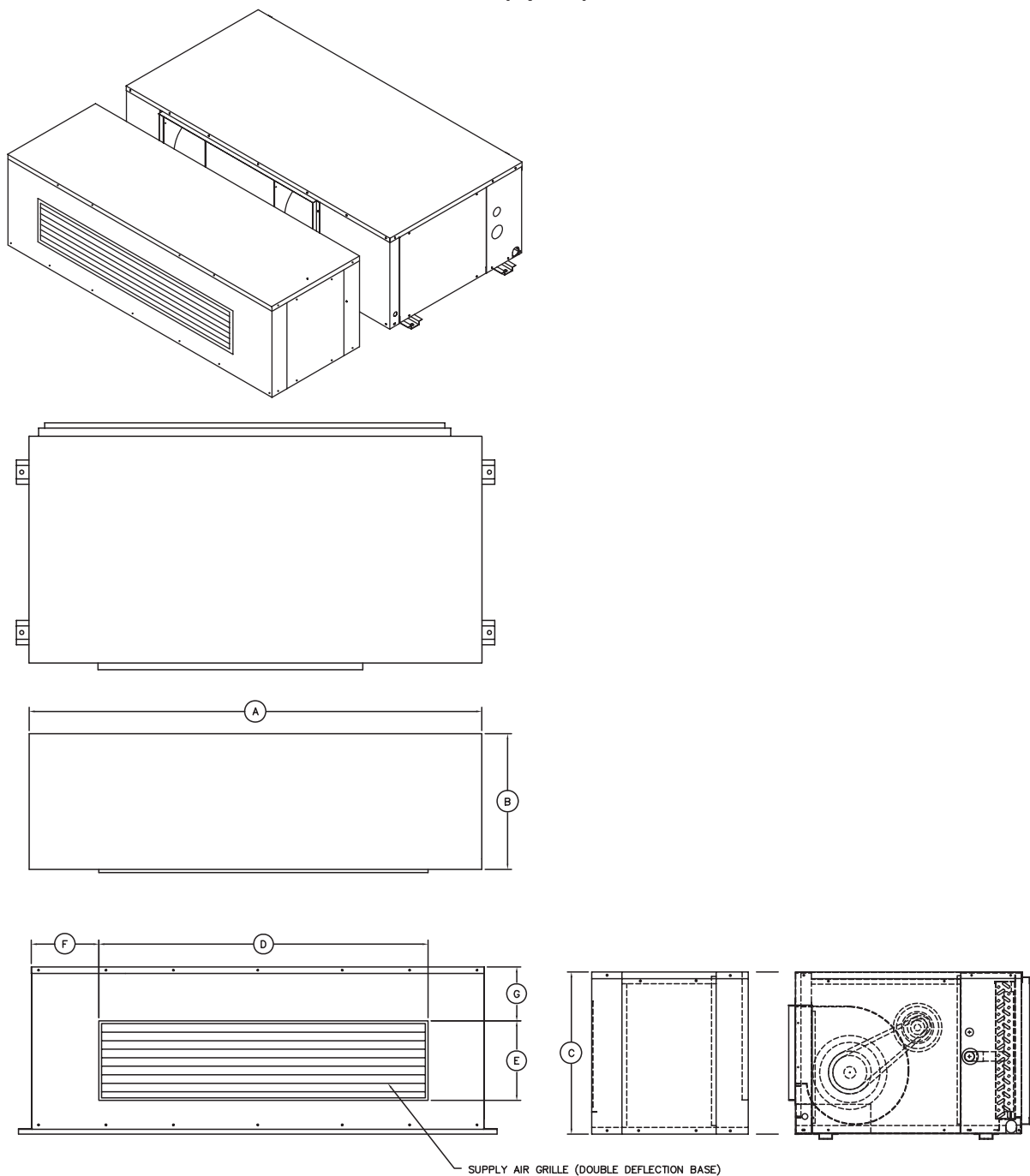

Model No.	Dimension (mm.)						
	A	B	C	D	E	F	G
TTH060	1312	499	503	762	305	275	100.5
TTH075	1312	499	503	965	305	173.5	100.5
TTH100	1680	499	503	1270	305	205	100
TTH120BD	1680	499	600	1330	350	172	152.5

Dimensional Data

TTH 120 FD
TTH 160 - 180

DIMENSIONAL DATA

MODEL	DIMENSION (mm.)						
	A	B	C	D	E	F	G
TTH160 / TTH120FD	1912	499	755	1502	550	202	102
TTH180	1912	499	755	1502	550	202	102

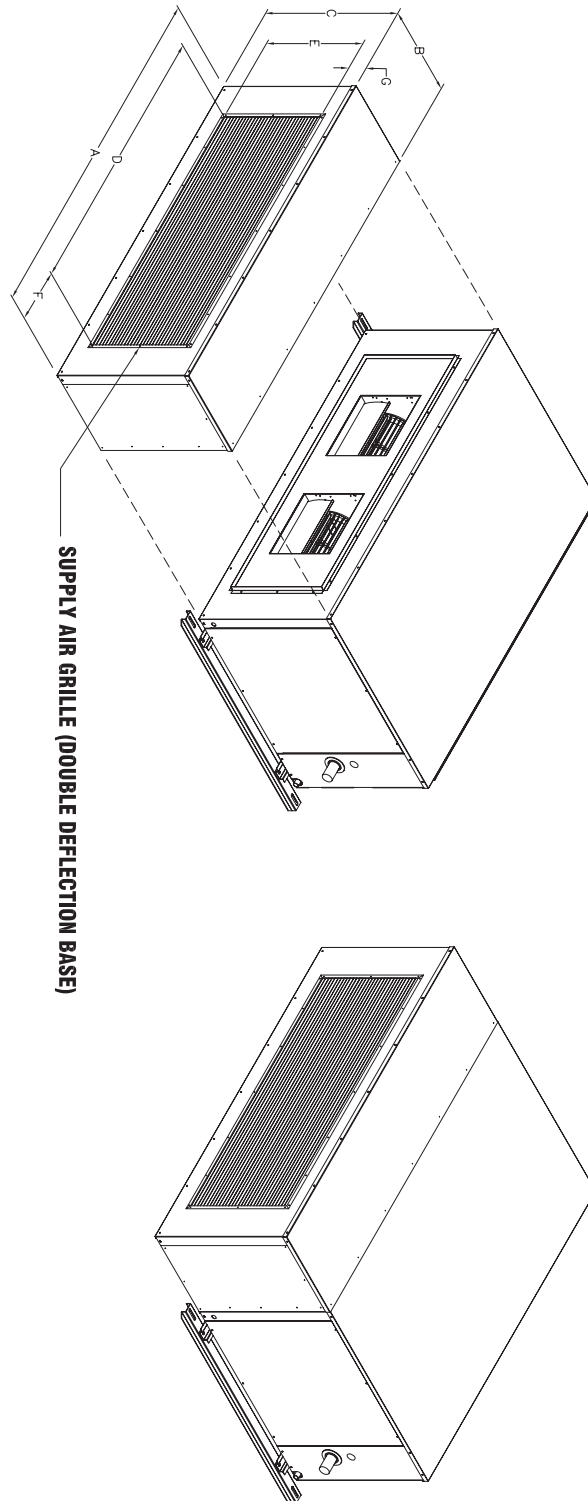

OUTLINE DIMENSION OPTION WITH DISCHARGE PLENUM

TTH210
TTH240

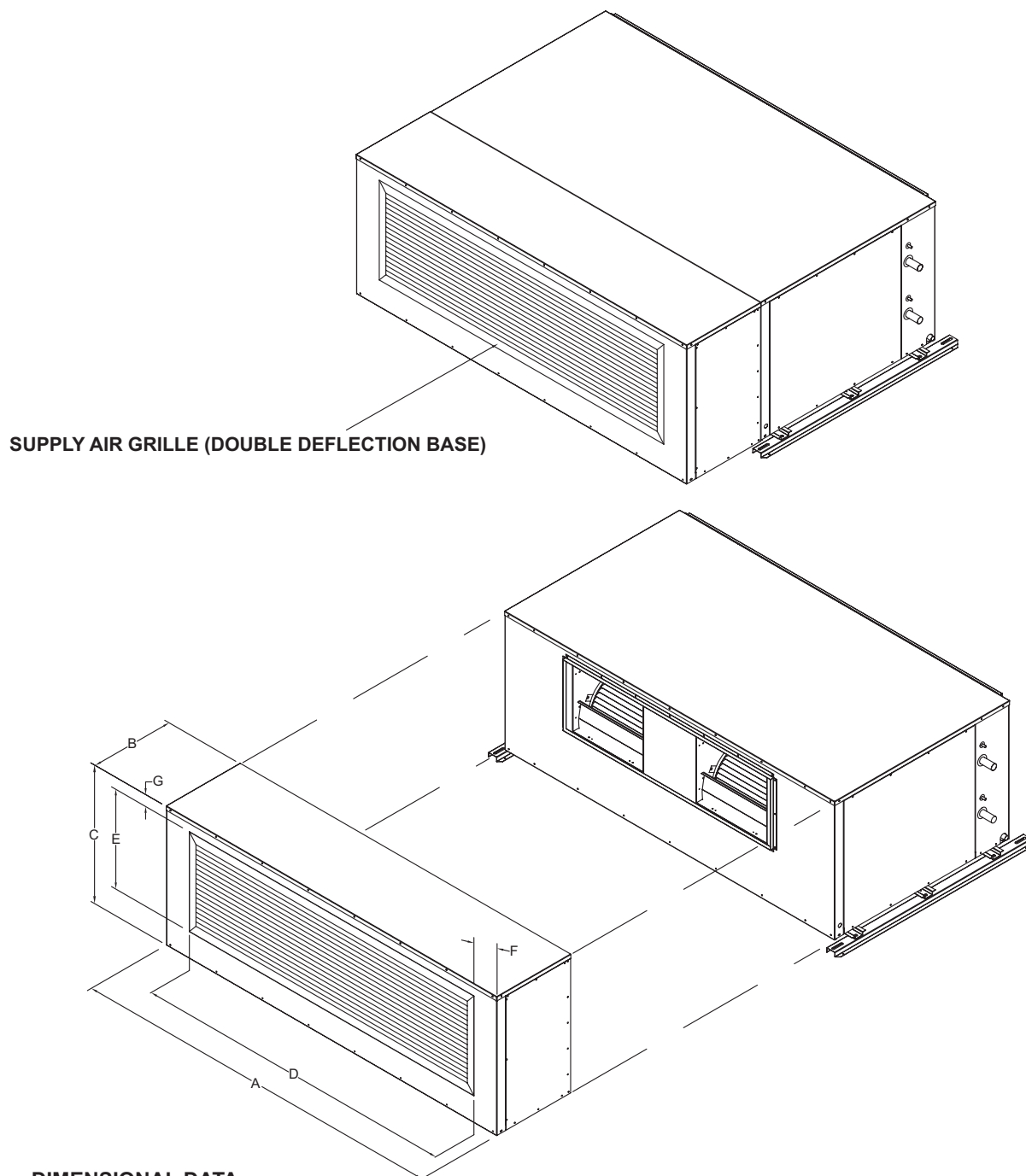

DIMENSIONAL DATA

MODEL	DIMENSION (MILLIMETER)																
	A	B	C	D	E	F	G	H	J	K	L	M	N	P	Q	R	
TTH210	2217	499	808	1944	614	134	51	-	-	-	-	-	-	-	-	-	
TTH240	2217	499	808	1944	614	134	51	-	-	-	-	-	-	-	-	-	



Operation and Start-up

Preparation

Perform the following checks and inspections before operating the unit:

Inspection Checklist

- Unit is mounted securely to the ceiling support rods (mounting units).
- Ductwork connections are complete.
- Coil connections are complete and tight.
- Condensate drain pan connections are complete and tight.
- Electrical connections are completed. Wiring is correct and in accordance with the wiring diagram.
- Ground connection is completed.
- Check and re-tighten if necessary set screws on the drive, fan pulley, fan bearings and wheel.
- Rotate fan by hand, to ensure that it runs freely and that there is no interference.
- Check that fan is centrally located in the housing, axially and radially.
- Check and re-tighten, if necessary, drive and bearing bolts, motor clamp plate bolts and isolator bolts.
- Check to ensure that pulley are correctly aligned and that shafts are parallel.
- Check belt tension as per instruction given in the maintenance section.

Start-Up Procedures

After completing all times under "Pre-Start-Up", the unit may be started and the following checks and adjustments performed.

- a. Measure the motor voltage and amps on all phases to insure proper operation. Compare these readings with the motor nameplate.
- b. Disconnect load and start motor to check the direction of rotation. If the rotation need to be changed, stop the motor completely and change the direction of rotation.
- c. After connecting the load, the motor should start quickly and run smoothly. If it does not, the power supply should be switched off at once and all connections, as well as the power supply, be re-checked before re-starting.
- d. In the event of excessive vibrations or unusual noises, the motor should be disconnected from the load and checked for poor alignment, loose mounting bolts, etc.
- e. When the motor has been operated under load for a short period of time, check that the operating current totally with the nameplate current.

Maintenance

Warning

Disconnect electrical power source and secure in disconnected position before servicing the unit. Failure to do so may result in personal injury or death from electrical shock.

Monthly Inspection

1. Check condition of air filters and replace them if necessary.
2. Check the drain pan to be sure that it is clean and free to carry the flow of condensate through the drain line.
3. Check the coil surface for cleanliness. Clean if necessary.

Yearly Inspection

1. Replace filters.
2. Check coil surface. Clean by vacuuming or flushing with cold water. Do not use steam or hot water.
3. Carry out checks as detailed in inspection checklist in the Operation Section.
4. Inspect the condition of the evaporator fan belt and replace if necessary. The belts fitted to TTH units cannot achieve design performance without the correct tensioning.
5. Check condition of vibration isolators, replace if there is any sign of wear, loosening or material deterioration.
6. Check fan bearings for noisy operation and excessive lubricant leakage. Replace if necessary.
7. Inspect the condensate drain pan and condensate piping to make sure they are clear and will carry away all water.
8. Inspect the control panel wiring to make sure connections are tight and insulation is intact.

Change/Clean Filters

Change or clean air filters at least twice a year. Filters will be required more frequent care under high load condition or dirty air. A clogged air filters reduces airflow, cooling capacity and increases energy usage.

To clean permanent filters, remove the filter media and wash it in water to remove dust, dirt and lint; allow to dry thoroughly before re-installing in the units. Do not rub or wring.

Permanent filters can also be cleaned by blowing with compressed air in opposite direction of filter airflow.

Belt Maintenance

Clean fan belts and pulleys with a dry cloth. Oil and grease must be kept off belts. The use of a belt dressing is not recommended. When replacing belts, use a matched set.

Do not force belts onto pulleys, but adjust motor position to allow mounting and then re-tighten.

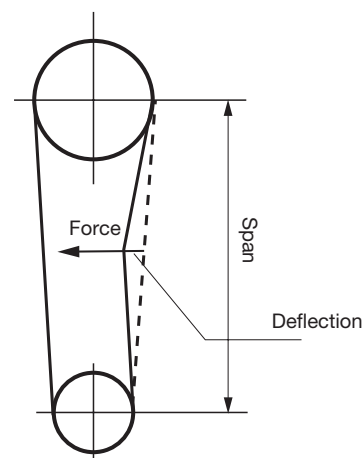

Figure 6
Belt Tension Measurement

To measure belt tension, use a belt tensioner as shown in Figure 6. Determine actual deflection by depressing one belt with the belt tensioner and then adjust the belt tension to the correct pounds force and tighten all setscrews to the proper torques.



Trouble Shooting

System Faults	Power Supply	High Voltage Wiring	Low Voltage Wiring	Control Transformer	Thermostat	Low Voltage Fuse	Circuit Breaker	Relay (Fan)	Capacitor (Fan)	Thermal Cutout	Low Indoor Airflow	High Indoor Airflow	Refrig. Undercharge	Refrig. Overcharge	Excessive Evap. Load	Check Valve (Leaking)	Restriction LD Coil	Restriction (TXV or CAP)
Refrigerant Circuit																		
Head Pressure Too High												P						
Head Pressure Too Low										P				P				
Suction Pressure Too High										P		P	P	P				
Suction Pressure Too Low									P		P					P	P	
Indoor Coil Frosting									P	P					P	P		
Liquid Floodback (TXV)														P				
Liquid Floodback (Cap. Tube)															P			
Electrical																		
I.D. Motor Won't Start	P	P	P	P	P	P	P	P	P									

P Primary Causes - S Secondary Causes

Trouble Shooting

Safety recommendations

To avoid accidents and damage, the following recommendations should be observed during maintenance and service visits:

1. The maximum allowable pressures for system leak testing on low and high pressure side are given in the chapter "Installation". Always provide a pressure regulator.
2. Disconnect the main supply before any servicing on the unit.
3. Service work on the refrigeration system and the electrical system should be carried out only by qualified and experienced personnel.

Maintenance Contract

It is strongly recommended that you sign a maintenance contract with your local Service Agency. This contract provides regular maintenance of your installation by a specialist in our equipment. Regular maintenance ensures that any malfunction is detected and corrected in good time and minimizes the possibility that serious damage will occur. Finally, regular maintenance ensures the maximum operating life of your equipment. We would remind you that failure to respect these installation and maintenance instructions may result in immediate cancellation of the warranty.

Training

The equipment described in this manual is the result of many years of research and continuous development. To assist you in obtaining the best use of it, and maintaining it in perfect operating condition over a long period of time, the constructor has at your disposal a refrigeration and air conditioning service school. The principal aim of this is to give operators and maintenance technicians a better knowledge of the equipment they are using, or that is under their charge. Emphasis is particularly given to the importance of periodic checks on the unit operating parameters as well as on preventive maintenance, which reduces the cost of owning the unit by avoiding serious and costly breakdown.



เทรน (ประเทศไทย)
 เลขที่ 1126/2 อาคารวานิช 2 ชั้น 30-31 ถนนเพชรบุรีตัดใหม่
 แขวงมักกะสัน เขตราชเทวี กรุงเทพฯ 10400

Trane
www.trane.com

For more information, contact your local district office

Literature Order Number: TTH-IOM01-EN

Date: June 2014

Supersedes: Nov 2013

Stocking Location: Bangkok, Thailand

Trane has a policy of continuous product and product data improvement and reserves the right to change design and specifications without notice.